

Multi-Pro Service Kit Parts - Place O-Rings on diagrams below - shown approximate actual size*

PLEASE CALL RHINO IF YOU DO NOT HAVE ALL THESE PARTS IN YOUR KIT BAG

(# location indicated on exploded parts diagram)

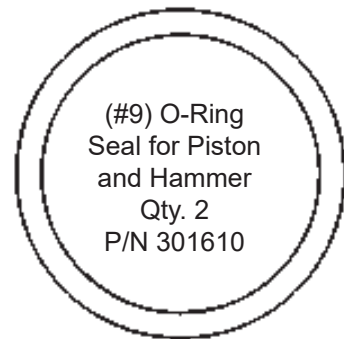

(#9) O-Ring Seal for Piston and Hammer
Qty. 2
P/N 301610

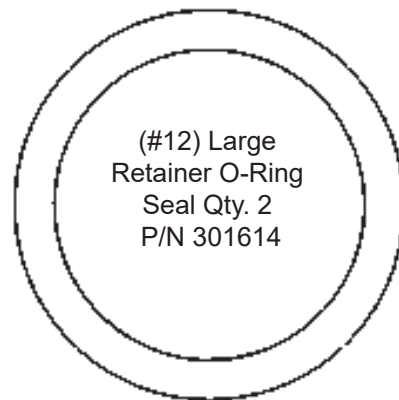

(#12) Large Retainer O-Ring Seal Qty. 2
P/N 301614

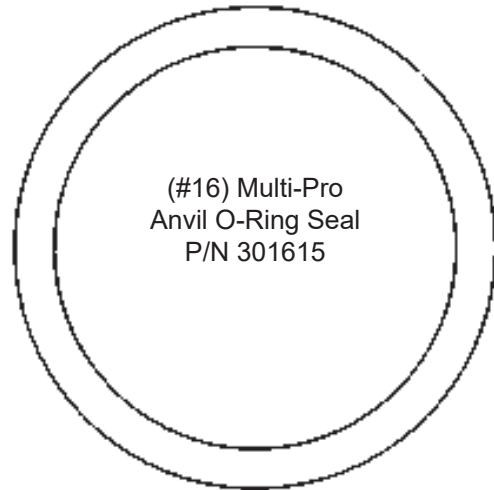

(#16) Multi-Pro Anvil O-Ring Seal
P/N 301615

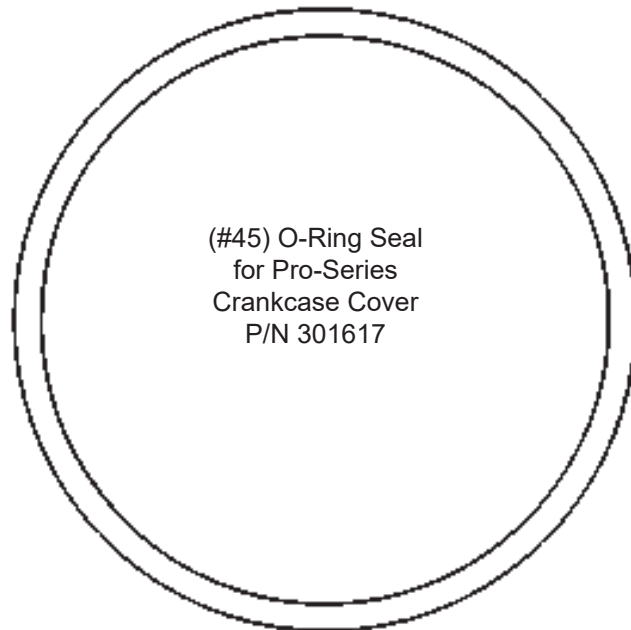

(#45) O-Ring Seal for Pro-Series Crankcase Cover
P/N 301617

*This is a quick reference guide to your sizes, they are as accurate as possible allowing for some variances.



- Multi-Pro Service Kit Part No. 301525:**
 (#9) O-Ring Seal for Piston and Hammer (2) P/N 301610
 (#45) O-Ring Seal for Pro-Series Crankcase Cover P/N 301617
 (#12) Large Retainer O-Ring Seal (2) P/N 301614
 (#16) Multi-Pro Anvil O-Ring Seal P/N 301615
 (#22) Multi Pro Lower Body Bolts (4) 300701
 (#21) Multi Pro Lock Washer (4) 300750
 Rhino Pro-Series Lubricant (1) 300500
 Loctite 518 Gasket Eliminator 6ml. (1) 995612

RHINO TOOL COMPANY, INC.
 P.O. Box 111 | Kewanee, IL 61443

Please visit: www.rhinotool.com to find your nearest servicing Rhino Dealer



Rhino® Multi-Pro™ Service Kit - Part No. 301525

MODELS: 301002 / 301003 / 301007 / 301012 / 301014

Serial Numbers: **5005459** or **XA04599** and higher no longer use parts shown in **RED** below

Rhino® Multi-Pro™ Standard Configuration

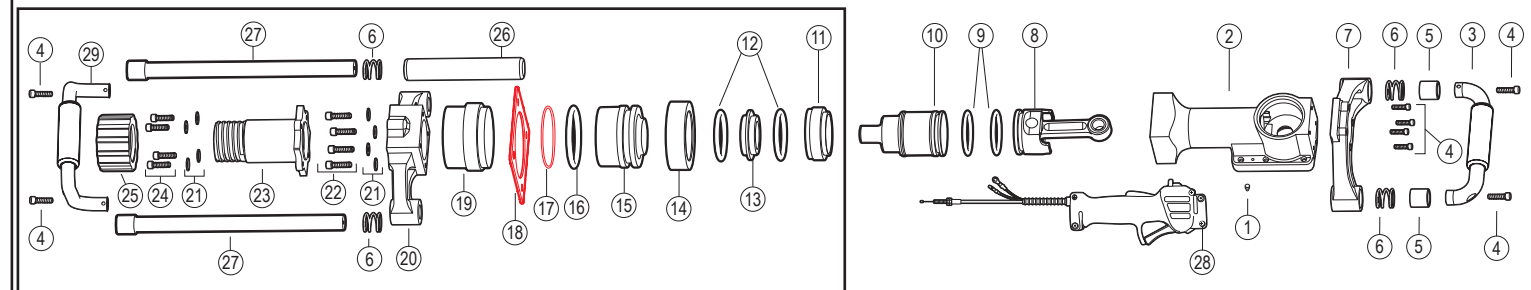

Enlarged to show detail - **obsolete parts in red**

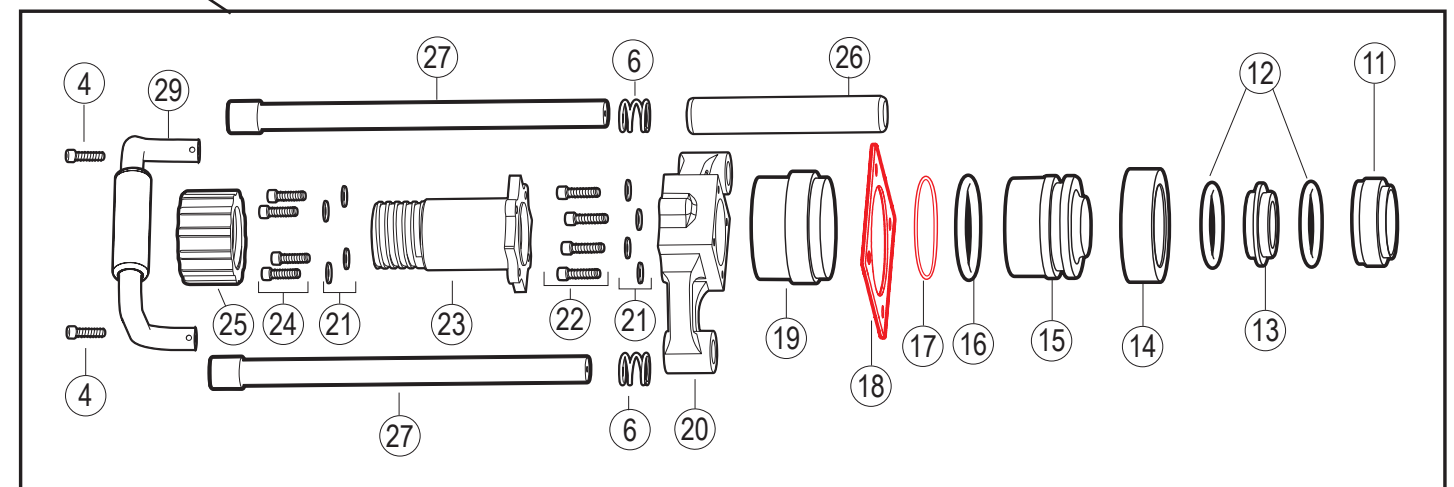

- 1: Remove the Chuck-Lok Locking Nut (#25) from the Master Chuck (#23)
- 2: Remove the four 5/16" bolts (#24) and Washers (#21) from the Master Chuck (#23). Using a 1/4" Hex Wrench. Set the Master Chuck and Chuck-Lok Locking Nut aside.
- 3: Loosen the two bolts on the Throttle (#28) using a 5/32" Hex Wrench. **Do Not Remove Them.**
- 4: Mark the top side of the Handle Collars (#5) with a black marker or alike as they are specific on the direction they are installed. Using a 1/4" Hex Wrench, remove the two 5/16" bolts (#4) recessed in the Top Handle Assembly (#3). **Caution as the Handle Collars (#5) are under tension from the Handle Springs (#6).** Set aside.
- 5: Using a 1/4" Hex Wrench, remove the four 5/16" bolts (#22) and washers (#21) from the lower body (#20) and discard. Take down the Lower Body with both Side Handles (#27) and Lower Handle Assembly (#29) attached. Remove the Throttle (#28) by sliding off from the side handle.
- 6: Discard the used O-Ring (#17) and Gasket (#18) - your model may not contain these parts. Clean the remaining gasket adhesive from the Lower Body (#20) and Body Assembly (#2). It is important that both surfaces are clean of gasket material and adhesive.
- 7: Extract the Anvil O-ring Cup (#14) and its components; Large Retainer (#13) and Large Retainer O-rings (#12) from the Lower Body (#20). Take the components out from the Anvil O-ring Cup (#14). Discard Anvil O-ring Cup (#14) and Large Retainer O-rings (#12) Inspect Large Retainer (#13) for damage. Use the NEW Anvil O-ring Cup and O-rings (#12) from Service Kit and lube all components with supplied grease. Make sure that the Large Retainer (#13) is positioned correctly with the large radius facing upward, as shown on



Rhino® Multi-Pro™ Service Kit - Part No. 301525

MODELS: 301002 / 301003 / 301007 / 301012 / 301014

Serial Numbers: 5005459 or XA04599 and higher no longer use parts shown in RED below

Rhino® Multi-Pro™ Lower Body and Crankcase Configuration

Enlarged to show detail - obsolete parts in red

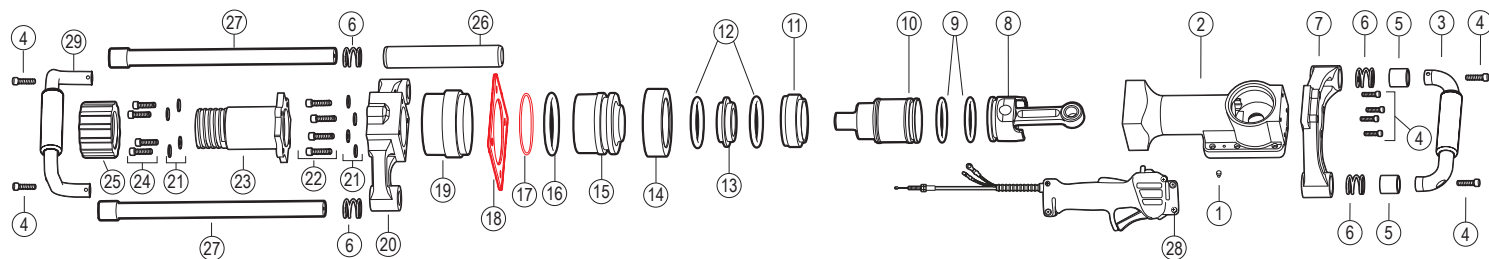

in (Fig. 1). Incorrect installation can result in damage to the driver.

8: Remove the Anvil (#15) from the Sleeve (#19) in the Lower Body (#20). Remove the Anvil O-ring (#16) and discard. Install Anvil O-ring from Service Kit. Remove the Sleeve by pushing from bottom side of Sleeve using a press and discard. Press in **NEW** Sleeve. Lubricate the Anvil O-ring and Sleeve with supplied grease. Reseat the Anvil (#15) into the Sleeve. Re-Install the **NEW** Anvil O-ring Cup with components into the Sleeve. Discard the Anvil O-ring Retainer (#11) and install the **NEW** Anvil O-ring Retainer on top of the Anvil O-ring Cup and its components. The Anvil O-ring Retainer only installs one way, installing it wrong may result in damage to the driver.

9: Replace used Large Retainer O-rings (#12) with new ones from your service kit. Lube all components. Make sure that the Large Retainer (#13) is positioned correctly, as shown in (Fig. 1) incorrect installation can result in damage to the driver. Re-install the Anvil O-ring Cup with components into the sleeve.(Fig. 2)

10: Install the Anvil O-ring Retainer (#11) on top of the Anvil O-ring Cup and its components. The Anvil O-ring Retainer only installs one way, installing it wrong may result in damage to the driver. Set the Lower Body (#20) and all parts attached to the side and focus on the Body Assembly (#2). (Fig. 3)

11: Remove the Crankcase Cover (#44) and discard Crankcase Cover O-ring (#45). Lube and install the new Crankcase Cover O-ring from the kit. Set aside.

12: With a black marker, or alike, mark the Piston Assembly (#8) to re-install it in the same orientation when reassembling. **Note that the Crank Pin (#46) is left hand thread.** Use a 7/8 deep-well socket to remove the Crank Pin. Inspect the Crank Pin and threads for damage as well as the Crank Shaft (#48) threads. Extract the Piston Assembly and Hammer (#10) from the Body Assembly (#2) and remove the O-rings and discard. Inspect the Self Lubricating Bronze Sleeve Bearing in the Connecting Rod of the Piston Assembly and check either for wear or out of roundness. Piston Assembly is only available as a complete assembly.

Fig. 1 - Assembly order of steps 8 - 10

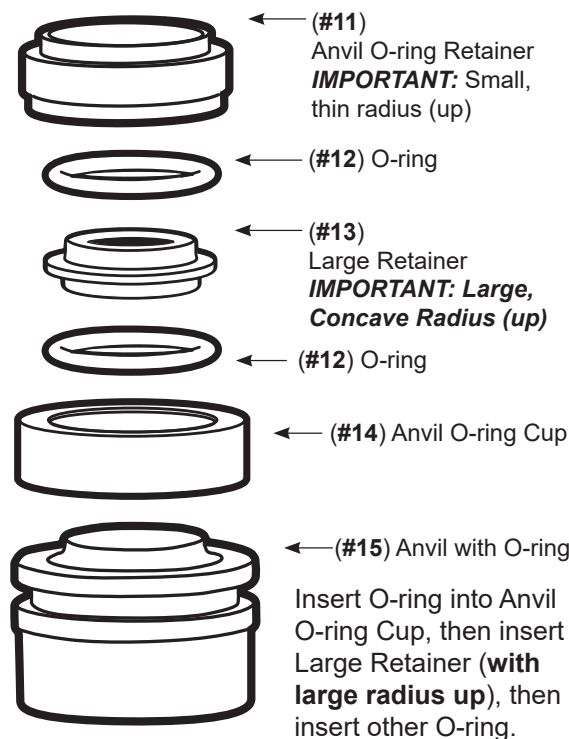

(#13) Large Retainer: Large, concave Radius (up)

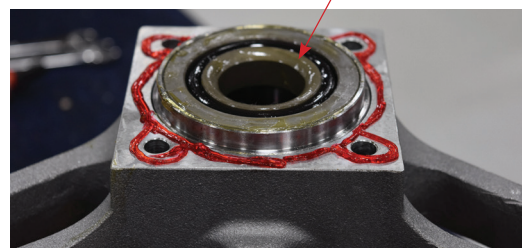

Fig. 12 - Proper preparation of the Lower Body retainers, o-rings and Loctite 518 (red) before re-attaching to the Upper Body Assembly



Rhino® Multi-Pro™ Service Kit - Part No. 301525

MODELS: 301002 / 301003 / 301007 / 301012 / 301014

Serial Numbers: 5005459 or XA04599 and higher no longer use parts shown in RED.

Lube the Hammer and Piston Assembly O-ring groove and install one of the Piston/Hammer O-rings (#9) from the kit on each. Set aside.

13: Clean all lubricant from the Crank Pin (#46) and lay on a shop towel along with the four Chuck Bolts (#24) with Washers (#21) installed, four Lower Body Bolts (#22) with Washers installed, and two Handle Bolts (#4). Including the Crankshaft (#48) and Side Handle Assembly's (#27) spray all threads with Loctite N 7649 Primer and let dry. Check all washers as they are the two piece design shown (Fig. 4)

14: Clean out all lubricant from the Body Assembly (#2). Install Piston Assembly (#8) with the connecting rod facing the top of the driver and mark made in Step 12 facing outward. Locate the Self Lubricating Bronze Sleeve Bearing in the Connecting Rod of the Piston Assembly and align it with the threads in the Crank Shaft (#48). Apply Loctite 243 Threadlocker to the Crank Pin Threads and install it through the connecting rod of the piston assembly. **Crank Pin has left hand threads.** Torque to 360 in/lbs. or 31 ft/lbs. Install Hammer (#10) with the Hammer O-ring (#9) towards the top of the driver.

15: Obtain the Lower Handle/Body Assembly. Make sure the mating surfaces of the Lower Body (Fig. 2) and Body Assembly (Fig. 3) are clean of grease. Place a bead of of the supplied Loctite 518 around the outside of the Sleeve on the Lower Body surface and around bolt holes of Lower Body (#20) (Fig. 2). Apply Loctite 243 Thread locker to the four NEW Lower Body Bolts (#22) with Washers (#21) and four threaded holes in the Body Assembly. Install the Throttle (#28) on the Side Handle Assembly (#27). Install the Lower Handle/ Lower Body Assembly on to the Body Assembly and torque to 251 in/lbs. or 21ft/lbs. Place the top of both side handle assemblies (#27) through the top handle bracket (#7) and slide the Throttle (#28) to its lowest point and tighten the upper bolt to hold the Handles (#27) in their most up position. Make sure the Handle Springs (#6) are installed in the Top Handle Bracket (#7).

16: Install the handle collars (#5) with the mark made in Step 4 in the up position. Insert both handle bolts (#4) into the Top Handle Assembly (#3) so that the threads are exposed. Apply Loctite 243 Threadlocker to the bolt threads and install the Top Handle Assembly on to the Handle Collars. Apply downward force to compress the Handle Springs (#6) and torque the Handle Bolts to 132in/lbs. or 11 ft/lbs.

17: Loosen the top bolt on the throttle, move it to the final position and hand tighten bolts with a 5/32" Hex Wrench. (Be careful not to overtighten) Apply Loctite 243 Threadlocker to Chuck Bolts (#24) and threaded holes in Lower Body (#20). Position the Master Chuck (#23) up to the Lower Body (#20) and install Chuck Bolts. Torque to 251in/lbs or 21 ft/lbs. Hand tighten the Chuck-Lok Locking Nut (#25) onto the Master Chuck (#23).

18: Fill the crankcase with one tub of lubricant from your service kit. With a 7/8" Deep-well Socket spin the Crank Pin (#46) counter-clockwise feeling for any binding on the Piston Assembly (#8). Locate Crankcase Cover (#44) with Crankcase Cover O-ring (#45) from Step 11 and install. Hand tighten only.

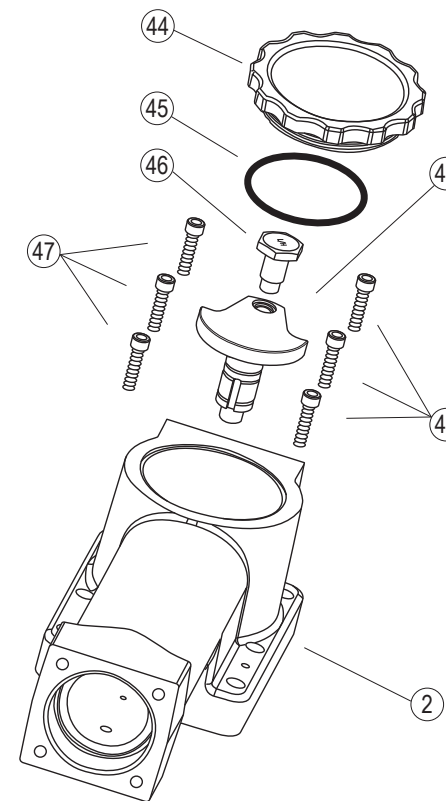

Fig. 3 - Body Assembly - steps 11 - 14

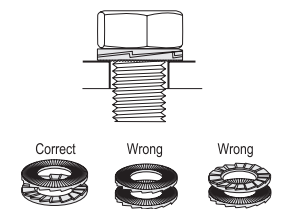

Fig. 4 - Two piece locking washer design.



See our service video playlist on YouTube for more information on installation.

Online at:
<https://bit.ly/3ahlp1x>



RHINO TOOL
service manuals

OR Scan this QR Code to find service information for any Rhino Tool Product