



SERVICE MANUAL

Service, Repair & Replacement Parts Information

EPIC[®] 300 Series Two-Man Hole Digger

Model: 332H/348H

Form: PGSM08042003EU, Version 1.0, Original Instructions

- Do not discard this manual.
- Keep manual readily available for reference during operation or when servicing product.
- Before operation, read and comprehend operator manual content.
- **Customer Service:** 001 507 451 5510
- **Customer Service Telefax:** 001 507 451 5511
Note: There is no charge for Customer Service.
- **Internet Address:** <http://www.generalequip.com>
- **Email:** general@generalequip.com
- **Mailing Address:**
General Equipment Company, 620 Alexander Dr. S.W., P.O. Box 334, Owatonna, MN 55060, USA

EUROPEAN CE REPRESENTATIVE

- **Customer Service:** (+31) 5 23 63 82 86
- **Internet Address:** <http://www.eurogate-international.com>
- **Email:** info@eurogate-international.com
- **Mailing Address:** Eurogate International, Galilieistraat 6, 7701 SK Dedemsvaart, The Netherlands

Product covered by this manual complies with mandatory requirements of 2006/42/EC.

Copyright 2021, General Equipment Company, All rights reserved.



TABLE OF CONTENTS

1	INTRODUCTION	1
2	SAFETY SYMBOLS.....	1
3	SAFETY INSTRUCTIONS	1
4	SERVICE/REPAIR INSTRUCTIONS	1
5	END OF LIFECYCLE	5
6	DECLARATION OF CONFORMITY	5
7	REPLACEMENT PARTS	6

1 INTRODUCTION

The Hole Digger is intended for use in digging holes outdoors in a variety of soil conditions. This manual is provided to assist in the service of specific, longer term maintenance items and replacement of parts when repairs are required.

Contents of this manual must be used in conjunction with the latest version Operator's Manual GOM08042003EU for products sold within European Union countries and GOM08042003US for all other destinations.

You have access to a team of dedicated, knowledgeable, support personnel that are ready to provide field support assistance. Our personnel can readily answer your questions or concerns regarding proper applications, service requirements and warranty related problems.

Please feel free to contact our European Representative or Customer Service Department during normal business hours using the contact information located on the front cover of this manual.

Sincerely,
The General Equipment Team

2 SAFETY SYMBOLS

The following safety alert symbols identify important safety messages in this manual. When you see these symbols, be alert to the possibility of personal injury and carefully read the message that follows.

SAFETY SYMBOLS & MEANINGS

Symbol	Meaning	Symbol	Meaning
	Action Required		General Warning
	Read Manual		Warning, Flammable Material
	Wear Ear Protection		Warning, Explosive Material
	Wear Eye Protection		Warning, Toxic Material
	Wear Protective Gloves		Warning, Electricity
	Wear Safety Shoes		Warning, Body Entrapment
	No Open Flame		Warning, Rotating Parts
	No Smoking		Warning, Hot Surface
	No Active Mobile Phone		Warning, Floor Level Obstacle
	No Food Or Drink		Warning, Drop Off
	No Trash Containers		Warning, Slippery Surface

3 SAFETY INSTRUCTIONS



- These safety instructions provide guidelines to promote safety and efficiency in servicing/repairing the Hole Digger.
- No warranty, guarantee or representation is made by manufacturer as to absolute correctness or sufficiency of any information or statement.
- Safety instructions are intended to deal with common practices and conditions encountered in servicing/repairing of Hole Digger and are not intended to be all inclusive.
- Not following instructions in this manual can result in property damage, personal injury and/or death.

BEFORE SERVICING/MAKING REPAIRS



1. BEFORE servicing and/or repairing Hole Digger, read this manual and appropriate Operator's Manual to gain familiarization with correct procedures. Refer to engine manufacturer material supplied with Hole Digger for engine related service and repair procedures. DO NOT service/repair Hole Digger unless designated service/repair technician has received adequate, professional instruction regarding proper procedures.
2. Visually inspect Hole Digger per Operator Manual MAINTENANCE INSTRUCTIONS STEPS 5 through 15.
3. Determine Hole Digger is in original, factory configuration and has not been modified in any manner. If questions arise about possible modifications, contact the European Representative or Customer Service Department BEFORE utilization. There is no charge for this service.

NOTE: Specifications and design are subject to change without notice or obligation. All specifications are general in nature and are not intended for specific application purposes. General Equipment Company reserves the right to make changes in design, engineering or specifications and to add improvements or discontinue manufacture at any time without notice or obligation. General Equipment Company and its agents accept no responsibility for variations which may be evident in actual products, specifications, pictures and descriptions contained in this publication.

4 SERVICE/REPAIR INSTRUCTIONS



The following information is intended for non-scheduled service/repair situations when specific issues arise that affect Hole Digger performance. Information is for reference only and is not intended to be all inclusive.

1. Use factory approved replacement parts/accessories only for servicing/repair purposes.
2. All service/repairs not described in this operator manual must be done by a dedicated service center following a specific service/repair manual.
3. STOP Hole Digger BEFORE performing service and repair per STOPPING HOLE DIGGER in OPERATING INSTRUCTIONS section of Operator's Manual.
4. DO NOT perform service and/or repair with Hole Digger mounted to 999 Series Display Stands. Stands are not designed and/or intended for these functions.
5. All engine service/repairs should be done according to contents of engine manufacturer material.

PRESSURE RELIEF VALVE SERVICING

Pressure relief valve is located on transmission cover top surface to relieve excess pressure in transmission due to heat rise. If valve becomes plugged, the following problems can occur:

- a) Transmission output driveshaft oil seal can push out of case, causing loss of transmission oil.
 - b) Gasket separating transmission cover and case can push out, causing loss of transmission oil.
1. To minimize issues, clean pressure relief valve when replacing transmission oil seal or centrifugal clutch rotor and shoe assembly.

IMPORTANT: Use safety type solvent. DO NOT use thinner, benzene, or other volatile solvents that will attack rubber/plastic components when cleaning Hole Digger. Provide adequate ventilation. Dispose of rags/solvents per international and local regulations.

TRANSMISSION OIL SEAL REMOVAL & INSTALLATION

The Hole Digger utilizes a fully enclosed, double reduction transmission for multiplying/transmitting engine torque to auger. Oil provides lubrication and heat dissipation for bearings, gears and clutch assembly.

Oil leakage between transmission output driveshaft and oil seal results from the following problems:

- a) Oil seal is worn due to extended operation.
- b) Inner sealing lip of oil seal is cut or nicked due to admission of foreign material or some sharp, abrasive object.
- c) Replacement oil seal was incorrectly installed in transmission.

IMPORTANT: In all above cases, a replacement oil seal must be correctly installed to prevent loss of transmission oil. The oil seal specified is an industry interchange standard and can usually be obtained from local supply sources.

Tools Required:

- 1 each, small, adjustable wrench
- 2 each, 1/2 inch (13 mm) wrenches
- 1 each, torque wrench 600 inch pound (68 N.m.) capacity with 1/2 inch (13 mm) and 15/16 inch (23.8 mm) sockets or,
- 1 each, torque wrench, 840 inch pounds (95 N.m.) capacity with 1/2 inch (13 mm) and 1-7/16 inch (36.5 mm) sockets
- 1 each, 1/2 inch (13 mm) drive socket wrench with 15/16 inch (23.8 mm) socket or,
- 1 each, 1/2 inch (13 mm) drive socket wrench with 1-7/16 inch (36.5 mm) socket
- 1 each, plastic hammer
- 1 each, three jaw gear puller
- 1 each, PN 345-7010 Service Tool
- 1 each, shop press

Parts Required:

- 1 each, PN 310-0101 transmission gasket
- 1 each, PN 471820 National® oil seal or industry equivalent
- 1 each, PN 15 alloy Woodruff key (if required)
- 1 each, PN 332-0350 large spur gear (if required)
- 1 each, PN 330H-0330 final driveshaft (if required)
- 1 each, PN 343H-0330 final driveshaft (if required)
- 2 each, PN 08125 bearing cones (if required)
- 1 each, container of Barium or Lithium based, lubricating grease
- 1 each, container of bearing/shaft locking grade, anaerobic adhesive/sealant
- 1 each, container of wheel bearing grease
- 1 each, PN 999-11 transmission and engine oil or equivalent.

NOTE: Oil seal removal and installation will require level working platform of sufficient size and appropriate height. As an alternative, transmission output driveshaft assembly can be securely mounted in suitable bench vise.

1. Drain fuel from fuel tank into a UL, CSA or UN marked, European ADR regulation approved fuel container and oil from transmission. If re-use is not possible, disposal must be carried out according to international and local environmental standards.
2. Remove transmission assembly bolts. Use plastic hammer to split/separate transmission cover and case. DO NOT damage alignment dowel pins. Temporarily store engine/transmission cover assembly in upright position in suitable location.
3. Remove clutch drum, primary gear/pinion gear assembly from transmission case.
4. Clean transmission case with safety type solvent.

IMPORTANT: Use safety type solvent. DO NOT use thinner, benzene, or other volatile solvents that will attack rubber/plastic components when cleaning Hole Digger. Provide adequate ventilation. Dispose of rags/solvents per international and local regulations.

5. Remove self-locking nut and flat washer. FIGURE 29

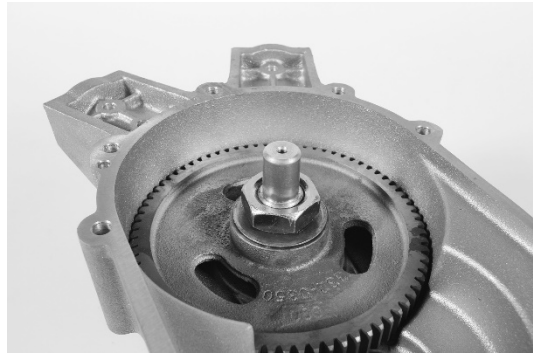

FIGURE 29

6. Using gear puller, remove large spur gear from driveshaft. FIGURE 30

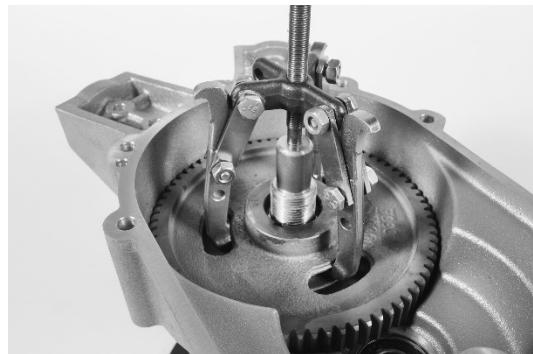

FIGURE 30

7. Remove Woodruff key and Nilos ring.
8. Using shop press/suitable blocking, support transmission case driveshaft area to prevent damage. As alternative, wood blocks and plastic hammer can be used. FIGURE 31

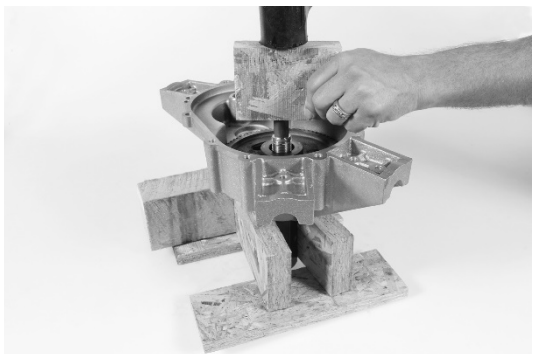

FIGURE 31

9. Press output driveshaft out of transmission through bearing in transmission case. Oil seal should also press out at this time.
10. Remove bearing cone from driveshaft and discard. Inspect driveshaft for chipping and/or cracking around Woodruff key area. If any damage is evident, replace driveshaft.
11. Inspect driveshaft in location where inner portion of oil seal contacts shaft for concentricity, scratches, chips or other imperfections. If depth of any groove cut into driveshaft is greater than .010 inch (0.25 mm), replace driveshaft.

NOTE: Unless inner sealing member of replacement oil seal turns on a concentric, smooth surface, oil will continue to leak.

12. Inspect replacement oil seal area where driveshaft rotates within seal and other portions of seal for scratches, chips or other imperfections which can cause oil to leak past seal. DO NOT use seal if any imperfections/damage is evident.
13. Pack cavity between inner and outer sealing members with Barium or Lithium based lubricating grease to minimize possibility of dry oil seal rotating on dry driveshaft during first few minutes of operation.

FIGURE 32



FIGURE 32

NOTE: LUBRIPLATE 105 is an approved lubricant.

14. Inspect transmission case oil seal cavity for signs of galling or shape distortion. Coat oil seal outside diameter with bearing/shaft, locking grade, anaerobic adhesive/sealant to help retain in position.
15. Slide oil seal over circular spacer of driveshaft with circular, twisting motion. The crimped side of oil seal faces away and opposite threaded end of driveshaft. DO NOT cut or nick oil sealing lips when installing seal.
16. Clean and inspect both bearing cones. Replace if excessive wear is evident. Repack both bearings with a suitable wheel bearing grease. Reinstall lower bearing cone on driveshaft against spacer.
17. Position transmission case on shop press with bottom of case facing up. Make sure case is not supported on any alignment dowel pins. Use Service Tool to press oil seal/driveshaft assembly into transmission case until firmly seated against machined shoulder. FIGURE 33

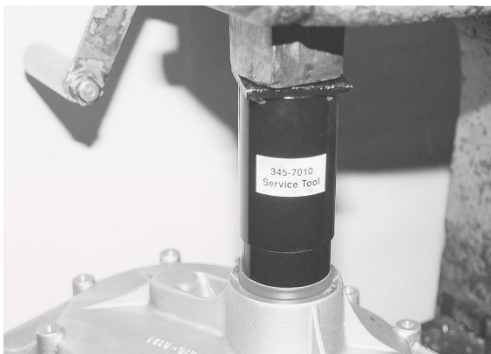

FIGURE 33

IMPORTANT: Cocking seal in the case contributes to seal failure. The service tool has approximately a 2.431 inch (61.7 mm) outside diameter. The inside diameter of tool is approximately 2-1/4 inch (57.2 mm). Apply face of service tool to the crimped bead of the oil seal. Too much pressure too close to center of the seal will distort or damage it.

18. If an arbor press is not available, tap oil seal into place with thin, wood block and plastic hammer. Position seal against machined shoulder of transmission case with bore at right angles to shaft. FIGURE 34

IMPORTANT: Keep blows to outside edge of oil seal to prevent damage. DO NOT hit oil seal with direct hammer blows under any circumstances.



FIGURE 34

19. Reinstall upper bearing cone, Nilos ring and Woodruff key on driveshaft. Coat Woodruff key area of driveshaft with light oil, Barium or Lithium based lubricant.
20. Reinstall large spur gear and flat washer.
21. Apply small amount of anaerobic adhesive/sealant to protruding threads of driveshaft.
22. Torque 1-1/4 inch (31.8 mm) self-locking nut to 60-70 foot pounds (81-95 N.m.). Determine flat washer is tight against large spur gear and is seated against Nilos ring. If not fully seated, use thin wooden block and plastic hammer to tap gear down into place. DO NOT , under any circumstances, hit large spur gear with steel hammer.
23. Tap both ends of driveshaft with plastic hammer to help set bearings. Loosen 1-1/4 inch (31.8 mm) self-locking nut and retorque to 60 foot pounds (81 N.m.). Recheck to determine flat washer is tight against large spur gear. Tap both ends of driveshaft with plastic hammer to help set bearings.
24. Attach torque wrench and 1-7/16 inch (36.5 mm) socket to 1-1/4 inch (31.8 mm) nut and rotate slowly to a maximum bearing drag of 30 INCH POUNDS (3.4 N.m.). This value should allow a MAXIMUM .003 inch (0.076 mm) of freeplay in the bearings. A greater amount of bearing drag will significantly decrease load capacity of bearings and contribute to premature bearing failure. If bearing value is less than or greater than the 30 inch pound (3.4 N.m.) value, readjust self-locking nut torque value to produce desire result. FIGURE 35

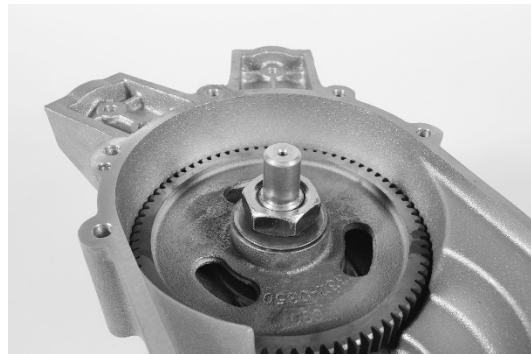

FIGURE 35

IMPORTANT: Flat washer must be tight against large spur gear plus, gear tight against Nilos ring to prevent driveshaft freeplay that exceeds allowable limit.

IMPORTANT: The precision machining tolerance between driveshaft diameter and large spur gear inside diameter can cause binding during assembly. Binding can prevent gear from firmly seating against Nilos ring and cause excessive driveshaft freeplay.

25. Reinstall primary gear and pinion assembly. If existing transmission gasket is damaged, replace. Realign transmission dowel pins when reinstalling engine/cover assembly. Torque all fasteners to 20 foot pounds (27 N.m.) in an "X" sequence.

IMPORTANT: Use of transmission gasket is required to provide adequate clearance. DO NOT substitute silicon material or gasket adhesive for factory approved gasket.

26. Rotate transmission output driveshaft and check for excessive noise and/or binding. If excessive noise and/or binding is evident, disassemble transmission and investigate for probable causes. Reassemble and retorquing bolts to specified amount. Recheck for excessive noise and/or binding.
27. Refill transmission with oil and engine fuel tank with fuel to appropriate levels.

CENTRIFUGAL CLUTCH ROTOR/SHOE ASSEMBLY REMOVAL & INSTALLATION

The Hole Digger utilizes an all metal centrifugal clutch rotor and shoe assembly that expands with engine RPM to engage clutch drum and transfer torque. The clutch rotor and shoe assembly is mounted to the engine crankshaft. Clutch assembly replacement symptoms include the following:

- a) Excessive clutch slippage and auger stalling at full, governed engine speed.
- b) Partial clutch engagement (and resulting auger rotation) at specified engine idle speed.

To replace clutch assembly, proceed as follows:

Tools Required:

- 2 each, 1/2 inch (13 mm) wrenches
- 1 each, three jaw gear puller (if required)
- 1 each, plastic hammer
- 1 each, torque wrench, 240 inch pound (27 N.m.) capacity with 1/2 inch (13 mm) socket
- 1 each, 1 inch (25.4 cm) capacity micrometer
- 1 each, feeler gauge set
- 1 each, 3/16 inch (4.7 mm) Allen wrench
- 1 each, 1/8 inch (3.2 mm), long handle type Allen wrench

Parts Required:

- 1 each, PN 3516 clutch drum/pinion assembly
- 1 each, PN 330H-0175 rotor/shoe assembly (units with Honda engine)
- 1 each, PN 310-0101 transmission gasket (if required)
- 1 each, PN 6 alloy Woodruff key (if required)
- 1 each, container of high temperature, anti-seize compound
- 1 each, container of wicking grade, anaerobic adhesive/sealant

NOTE: Centrifugal clutch rotor/shoe assembly removal and installation will require a level working platform of sufficient size and appropriate height.

1. Drain fuel from fuel tank into a UL, CSA or UN marked, European ADR regulation approved fuel container, oil from transmission and oil from engine. If re-use is not possible, disposal must be carried out according to international and local environmental standards.
2. Remove transmission assembly bolts. Use plastic hammer to split/separate transmission cover and case. DO NOT damage alignment dowel pins. Temporarily store transmission case assembly in upright position in suitable location.

NOTE: Remove primary gear/pinion gear assembly if attached to transmission cover when case and cover are split apart.

3. Clean transmission cover with safety type solvent.

IMPORTANT: Use safety type solvent. DO NOT use thinner, benzene, or other volatile solvents that will attack rubber/plastic components when cleaning Hole Digger. Provide adequate ventilation. Dispose of rags/solvents per international and local regulations.

4. Using 3/16 inch (4.7 mm) Allen wrench, remove access screw from side of transmission cover. FIGURE 36

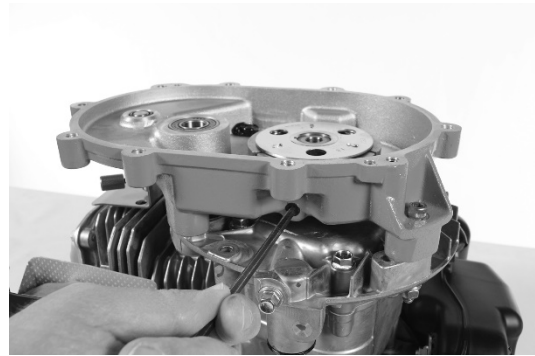

FIGURE 36

5. Using 1/8 inch (3.2 mm) Allen wrench, loosen two set screws retaining rotor/shoe assembly to engine crankshaft. FIGURE 37

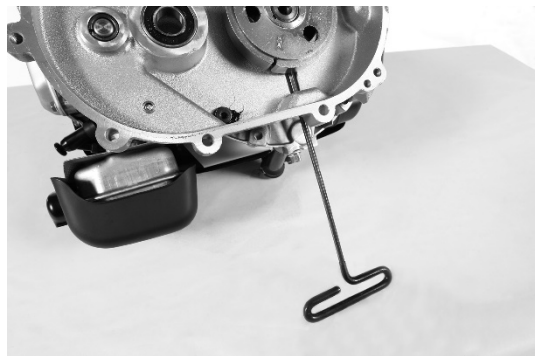

FIGURE 37

6. Using gear puller, remove clutch rotor/shoe assembly. FIGURE 38

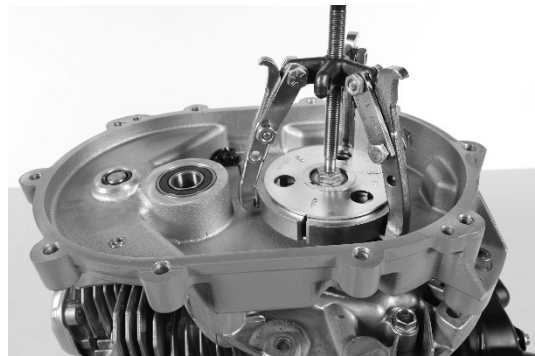

FIGURE 38

7. Inspect engine crankshaft and Woodruff key for signs of cracks and/or other damage. Replace key if wear and/or elongation are visible. Measure engine crankshaft with micrometer. Minimum allowable crankshaft diameter is .996 inch (25.3 mm). Maximum allowable TIR limit in gear pinion journal area of crankshaft is .003 inch (0.076 mm), relative to crankshaft. If crankshaft assembly is not within defined limits, replace.
8. Clean surface of crankshaft with safety type solvent.

IMPORTANT: Use safety type solvent. DO NOT use thinner, benzene, or other volatile solvents that will attack rubber/plastic components when cleaning Hole Digger. Provide adequate ventilation. Dispose of rags/solvents per international and local regulations.

9. Install replacement clutch rotor/shoe assembly on engine crankshaft with hub, including two set screws, toward crankcase. Tighten with 1/8 inch (13 mm) Allen wrench. FIGURE 39

IMPORTANT: End of engine crankshaft is set .030 (0.76 mm) below top edge of clutch rotor/shoe assembly hub. FIGURE 39

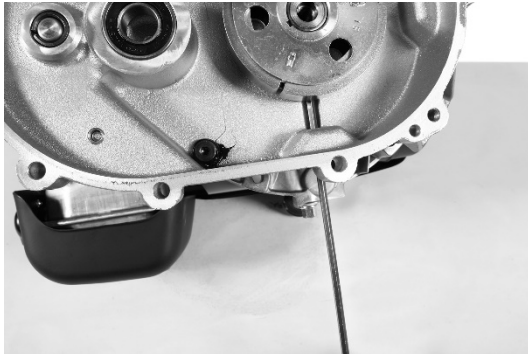

FIGURE 39

10. Apply wicking grade anaerobic adhesive to Allen screw to eliminate movement during Hole Digger operation. Using 3/16 inch (4.7 mm) Allen wrench, re-install access screw in transmission cover side. FIGURE 40

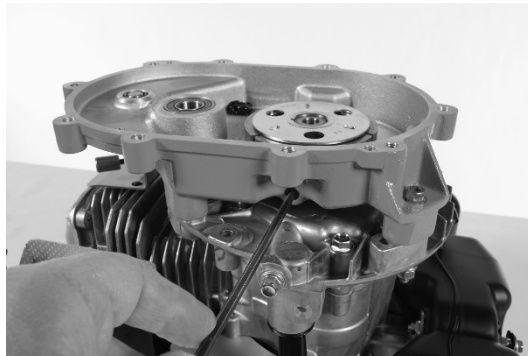

FIGURE 40

11. Apply small amount of high temperature, anti-seize compound to pinion gear journal area of transmission case output driveshaft. Install replacement clutch drum/pinion assembly on transmission case output driveshaft.
12. Reinstall primary gear/pinion assembly. If existing transmission gasket is damaged, replace. Realign transmission dowel pins when reinstalling engine and cover assembly. Torque all fasteners to 20 pound feet (27 N.m.) in an "X" sequence.

IMPORTANT: Use of transmission gasket is required to provide adequate clearance. DO NOT substitute silicon material or gasket adhesive for factory approved gasket.

13. Rotate transmission output driveshaft and check for excessive noise and/or binding. If excessive noise and/or binding is evident, disassemble transmission and investigate for probable causes. Reassemble and retorque bolts to specified amount. Recheck for excessive noise and/or binding.
14. Refill transmission, engine fuel tank and crank case with appropriate fluids to proper levels.

5 END OF LIFECYCLE



If the machine comes to the end of its lifecycle, destruction of the machine must be conducted according to international and local environmental regulations.

6 DECLARATION OF CONFORMITY

We, General Equipment Company, 620 Alexander Drive SW, P.O. Box 334, Owatonna, MN 55060, USA declare under our sole responsibility that the portable hole digger product: 332H

To which this declaration relates is in conformity with the following standards or standardization documents:

- EN-ISO 12100:2010

According to the provisions of the European directive:

- 2006/42/EC

Manufactured at: Owatonna, Minnesota 55060, USA
Beginning with serial number: 174809

Signature: Dennis Von Ruden

Position: President

Date: September 14, 2020

*Replacement Parts Diagram
332H & 348H Hole Digger
Equipped With Honda GXV160 Engine*

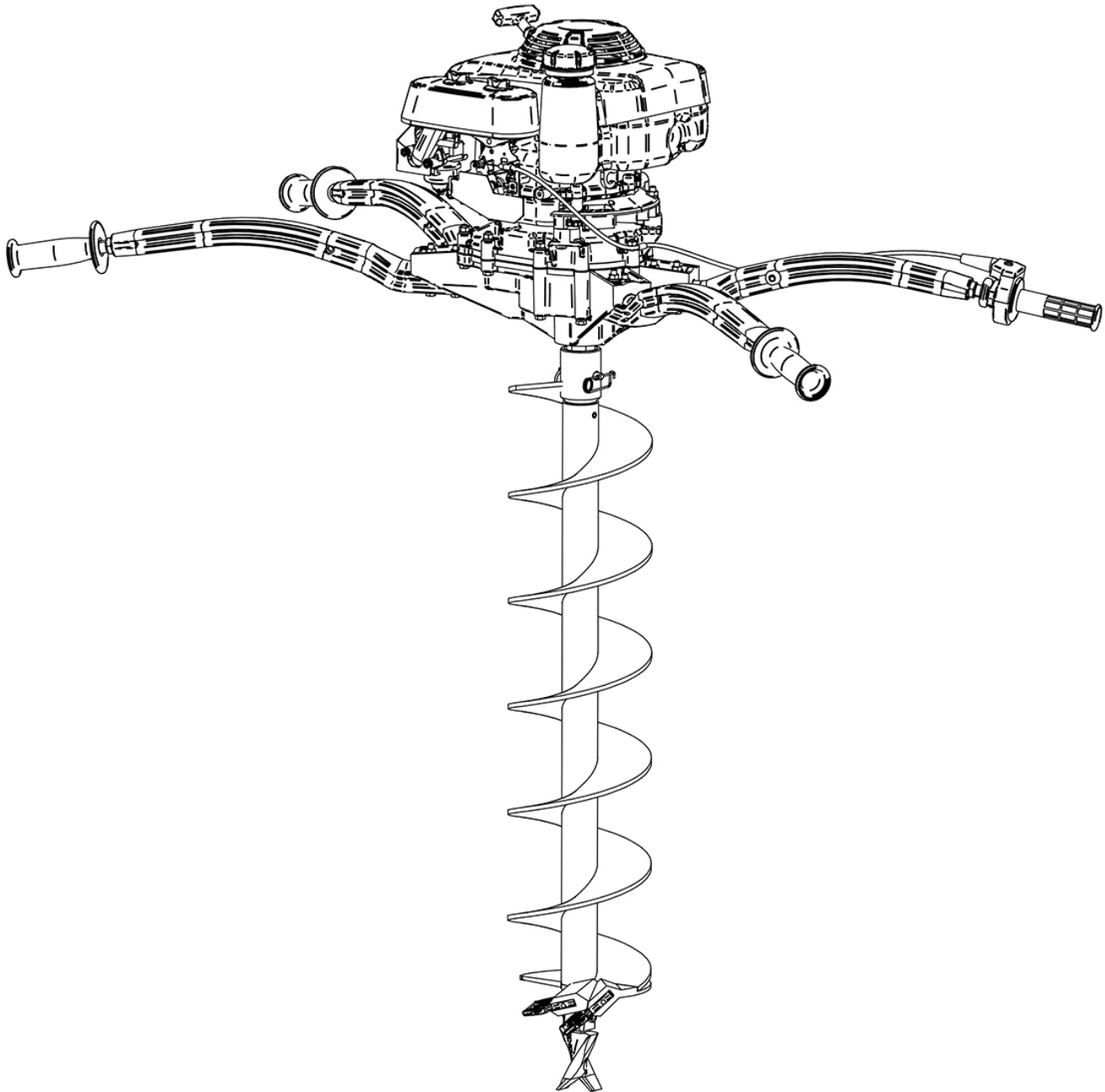

Replacement Parts Diagram Transmission Cover Assembly 332H & 348H Hole Digger [Beginning with Serial Number 174809]

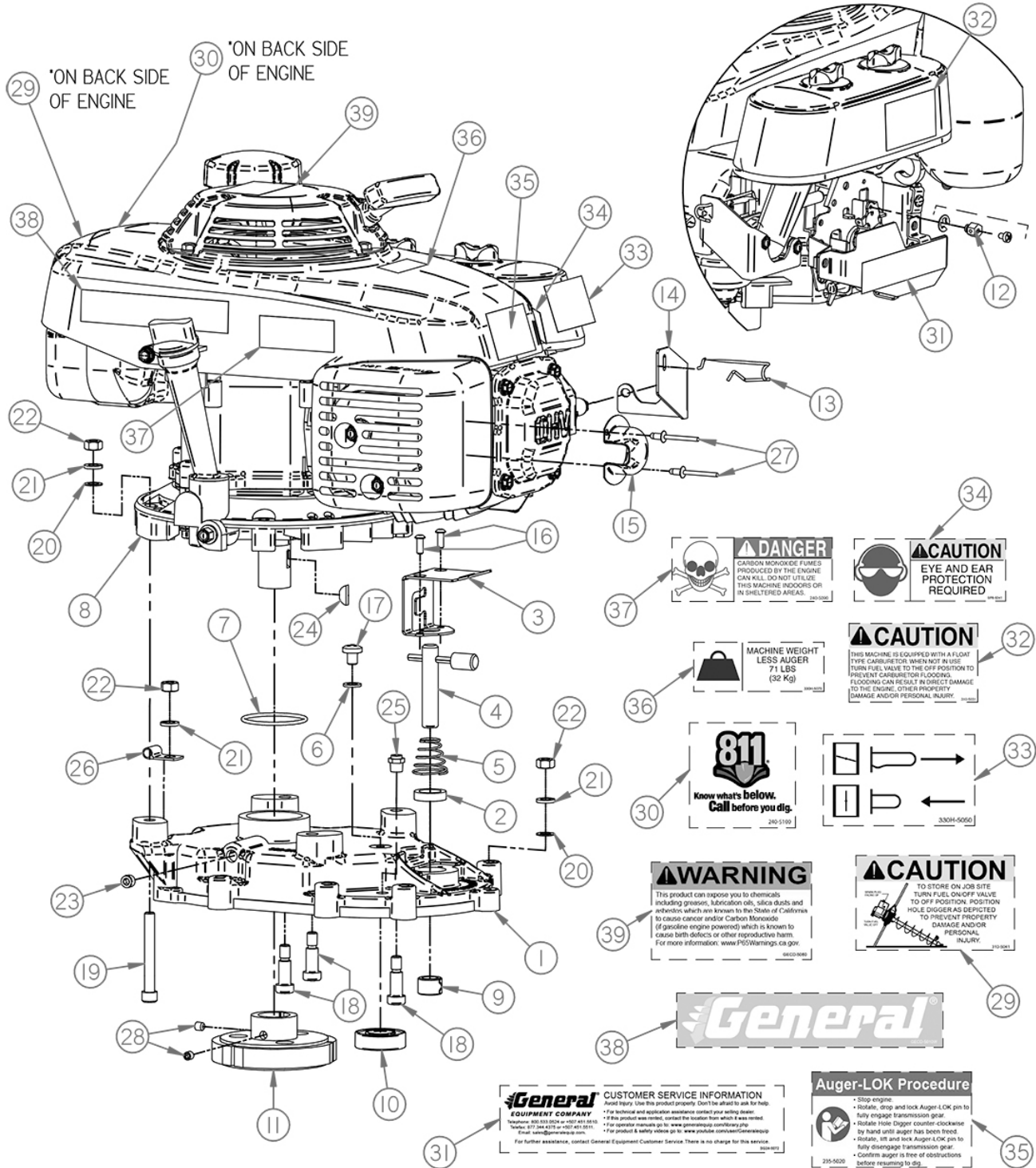

⚠ DANGER
CARBON MONOXIDE FUMES
PRODUCED BY THE ENGINE
CAN KILL. DO NOT UTILIZE
THIS MACHINE INDOORS OR
IN SHELTERED AREAS. 240-5100

⚠ CAUTION
EYE AND EAR
PROTECTION
REQUIRED

**MACHINE WEIGHT
LESS AUGER
71 LBS
(32 Kg)**

⚠ CAUTION
THIS MACHINE IS EQUIPPED WITH A FLOAT
TYPE CARBURATOR. WHEN NOT IN USE,
TURN FUEL VALVE TO THE OFF POSITION TO
PREVENT CARBURATOR FLOODING.
FLOODING CAN RESULT IN DIRECT DAMAGE
TO THE ENGINE, OTHER PROPERTY
DAMAGE AND/OR PERSONAL INJURY.

811
Know what's Below.
Call before you dig.
240-5100

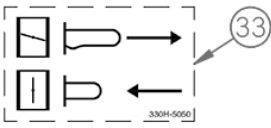

⚠ WARNING
This product can expose you to chemicals
including greases, lubrication oils, silica dusts and
exhaustion which are known to the State of California
to cause cancer and/or Carbon Monoxide
(if gasoline engine powered) which is known to
cause birth defects or other reproductive harm.
For more information: www.P60Warnings.ca.gov. 240-5100

⚠ CAUTION
TO STORE ON JOB SITE
TURN FUEL ON-OFF VALVE
TO OFF POSITION. POSITION
HOLE DIGGER AS DEPICTED
TO PREVENT PROPERTY
DAMAGE AND/OR
PERSONAL
INJURY. 240-5100



General EQUIPMENT COMPANY
CUSTOMER SERVICE INFORMATION
Avoid injury. Use this product properly. Don't be afraid to ask for help.
* For technical and applicable assistance contact your selling dealer.
* If this product was recalled, contact the location from which it was rented.
* For general information go to www.generalequipment.com/info
* For product & safety videos go to www.youtube.com/watch?v=General
For further assistance, contact General Equipment Customer Service. There is no charge for this service. 240-5100

Auger-LOK Procedure
• Stop engine.
• Rotate, drop and lock Auger LOK pin to fully engage transmission gear.
• Rotate Hole Digger counter clockwise by hand until auger has been freed.
• Rotate, lift and lock Auger LOK pin to fully disengage transmission gear.
• Confirm auger is free of obstructions before resuming to dig. 240-5100

Replacement Parts Diagram Transmission Cover Assembly 332H & 348H Hole Digger [Beginning with Serial Number 174809]

Reference Number	Part Number	Description	Quantity
1	332-0130A	Assembly, Cover, Transmission, (Includes Ref. 9 & 10)	1
2	471442	Seal, Oil	1
3	235-0230	Plate, Pin, Lock	1
4	235-0220	Assembly, Pin, Lock	1
5	235-0110	Spring, Pin, Lock	1
6	330H-0200	Washer, Nylon	1
7	330H-0020	Ring, O Type	1
8	GXV160UH2N5AH-BLK	Engine, Honda, GXV160	1
9	235-0140	Bushing, Spring-Type	1
10	6203-2RS-12	Bearing, Ball	1
11	330H-0175	Assembly, Rotor/Shoe, Clutch, (Includes Ref. 28)	1
12	330-0320	Assembly, Swivel	1
13	16611-ZG9-U80	Rod, Choke	1
14	17954-ZG9-U80	Bracket, Choke	1
15	330H-0040	Deflector, Exhaust, Gxv160	1
16	55030400	BHSCS, #10-24 X 1/2, ZY	2
17	37050300	PHMS, 5/16-18 X 3/8, ZY	1
18	62060601	Bolt, Shoulder, 3/8 X 3/4	3
19	60052000	SHCS, 5/16-18 X 2-1/2, ZY	1
20	AN-960-516L	Washer, Flat, 5/16, ZY	7
21	16050000	Washer, Lock, 5/16, ZY	8
22	18050000	Nut, Hex, 5/16-18, ZY	8
23	74020201	Plug, PTF, 1/8-27	1
24	6	Key, Woodruff, 5/32 X 5/8	1
25	5677	Valve, Relief	1
26	COV-0411	Clamp	1
27	46030100	Rivet, Pop, 3/16 X 1/8, SS	2
28	31040201	Screw, Set, 1/4-28 X 1/4, PF	2
29	310-5041	Decal, Storage	1
30	240-5100	Decal, 811	1
31	SG24-5072	Decal, Assistance	1
32	310-5031	Decal, Carb Off	1
33	330H-5050	Decal, Choke	1
34	SP8-5041	Decal, Caution, Eye/Ear	1
35	235-5020	Decal, Lock, Auger	1
36	330H-5070	Decal, Weight	1
37	240-5090	Decal, Danger	1
38	ZDBRPA265H01	Decal, BRPA265H, (Used on BRPA265H Only)	1
	ZDBRPA270H01	Decal, BRPA270H, (Used on BRPA270H Only)	
39	GECD-5060	Decal, Warning, Prop 65	1

*Replacement Parts Diagram
Transmission Case Assembly
332H & 348H Hole Digger
[Beginning with Serial Number 174809]*

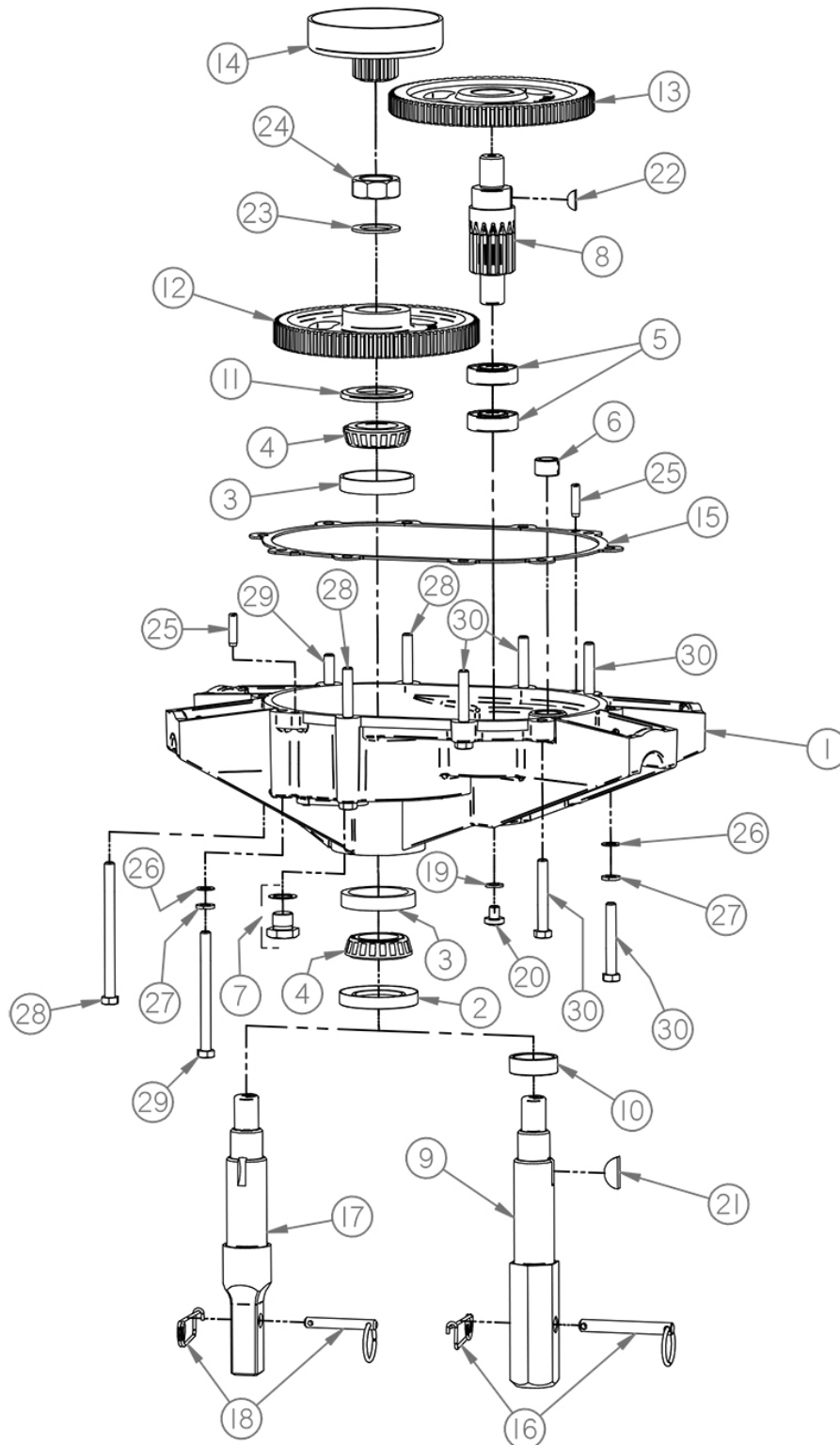

Replacement Parts Diagram Transmission Case Assembly 332H & 348H Hole Digger [Beginning with Serial Number 174809]

Reference Number	Part Number	Description	Quantity
1	332-0120A	Assembly, Case, Transmission, (Includes Ref. 3, 5 & 6)	1
2	471820	Seal, Oil	1
3	08231	Cup, Bearing	2
4	08125G	Cone, Bearing	2
5	6203-2RS-12	Bearing, Ball	2
6	235-0140	Bushing, Spring-Type	1
7	50100800A	Plug, Drain, Oil, W/Gasket	1
8	332-0310	Gear, Pinion, Secondary	1
9	332-0330A	Shaft, Drive, 1.38HEX, (Used on 332H, Includes Ref. 10)	1
10	332-0330-010	Bushing, Shaft, Drive	1
11	0812508231B-AV	Ring, Nilos	1
12	332-0350	Gear, Secondary	1
13	7034	Gear, Primary	1
14	3516	Drum, Clutch, W/Pinion	1
15	332-0100PAK2	Pak2, Gasket, Transmission	1
16	2121PAK3	Pak3, Pin, Auger, .375D	1
17	348-0330	Shaft, Drive, .88SQ, (Used on 348H)	1
18	2021PAK3	Pak3, Pin, Auger, .312D	1
19	330H-0200	Washer, Nylon	1
20	37050300	PHMS, 5/16-18 X 3/8, ZY	1
21	15	Key, Woodruff, 1/4 X 1	1
22	6	Key, Woodruff, 5/32 X 5/8	1
23	85160000	Bushing, Machine, 1.0NR	1
24	40160001	Nut, Jam, Hex, 1-14, Z	1
25	51040800	Pin, Dowel, 1/4 X 1	2
26	AN-960-516L	Washer, Flat, 5/16, ZY	9
27	16050000	Washer, Lock, 5/16, ZY	10
28	15053400	HHCS, 5/16-18 X 4-1/4, ZY	3
29	15053000	HHCS, 5/16-18 X 3-3/4, ZY	2
30	15051800	HHCS, 5/16-18 X 2-1/4, ZY	5

Replacement Parts Diagram Throttle Handle Assembly 332H & 348H Hole Digger [Beginning with Serial Number 174809]

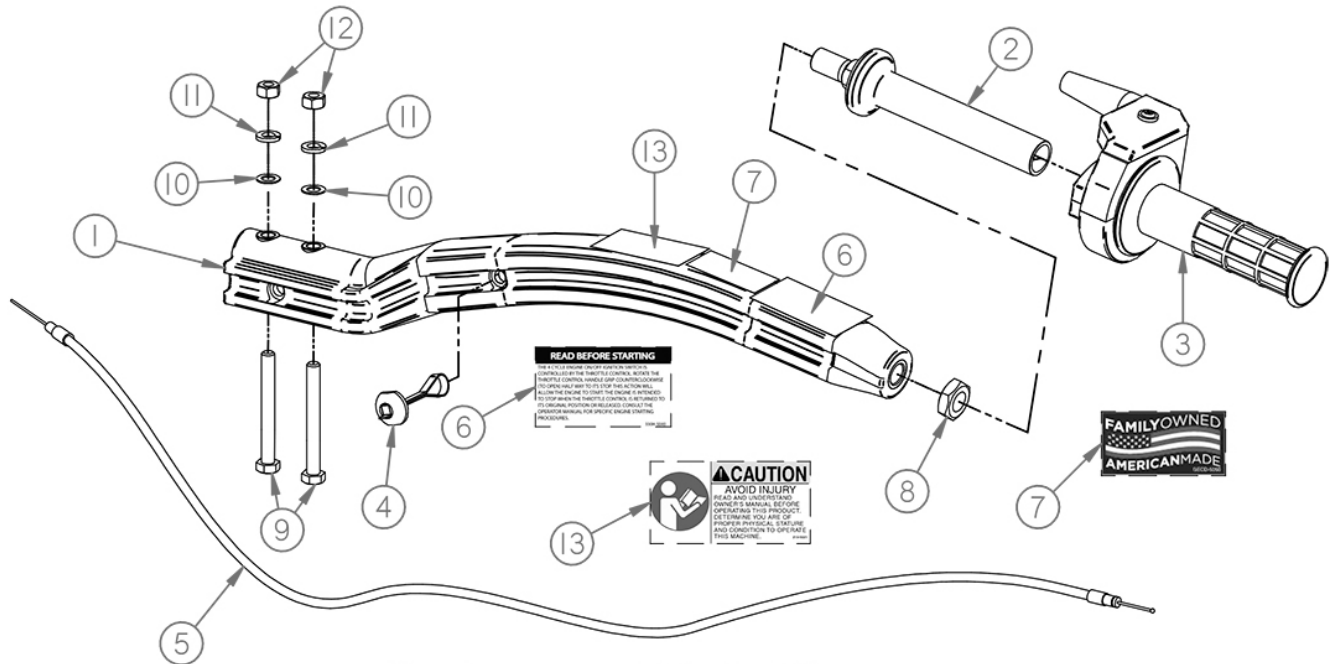

Replacement Parts Diagram Operator Handle Assembly 332H & 348H Hole Digger [Beginning with Serial Number 174809]

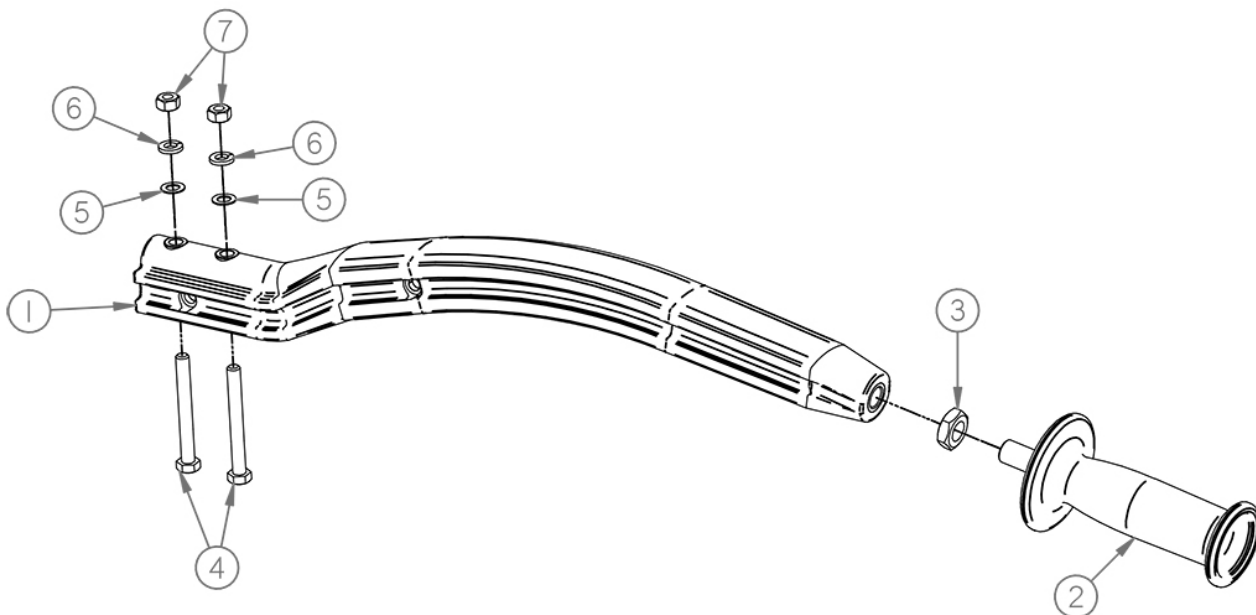

***Replacement Parts Diagram
 Throttle Handle Assembly
 332H & 348H Hole Digger
 [Beginning with Serial Number 174809]***

Reference Number	Part Number	Description	Quantity
1	235-0150	Handle, Throttle	1
2	235-0250	Grip, Handle, Throttle	1
3	310-0030	Assembly, Control, Throttle	1
4	235-0370	Tie, Cable, Throttle	1
5	310-0081PAK2	Pak2, Assy, Cable, Throttle	1
6	330H-5040	Decal, Ignition	1
7	GECD-5050	Decal, Family Owned, American	1
8	40090001	Nut, Jam, Hex, 9/16-18, ZY	1
9	15052200	HHCS, 5/16-18 X 2-3/4, ZY	2
10	AN-960-516L	Washer, Flat, 5/16, ZY	2
11	16050000	Washer, Lock, 5/16, ZY	2
12	18050000	Nut, Hex, 5/16-18, ZY	2
13	210-5021	Decal, Caution, Avoid Injury	1

***Replacement Parts Diagram
 Operator Handle Assembly
 332H & 348H Hole Digger
 [Beginning with Serial Number 174809]***

Reference Number	Part Number	Description	Quantity
1	235-0090	Handle, Operator	1
2	235-0240	Grip, Handle, Operator	1
3	40090001	Nut, Jam, Hex, 9/16-18, ZY	1
4	15052200	HHCS, 5/16-18 X 2-3/4, ZY	2
5	AN-960-516L	Washer, Flat, 5/16, ZY	2
6	16050000	Washer, Lock, 5/16, ZY	2
7	18050000	Nut, Hex, 5/16-18, ZY	2

Replacement Parts Diagram PN: 310-0030 Throttle Control Assembly For Use With 300 Series Hole Diggers

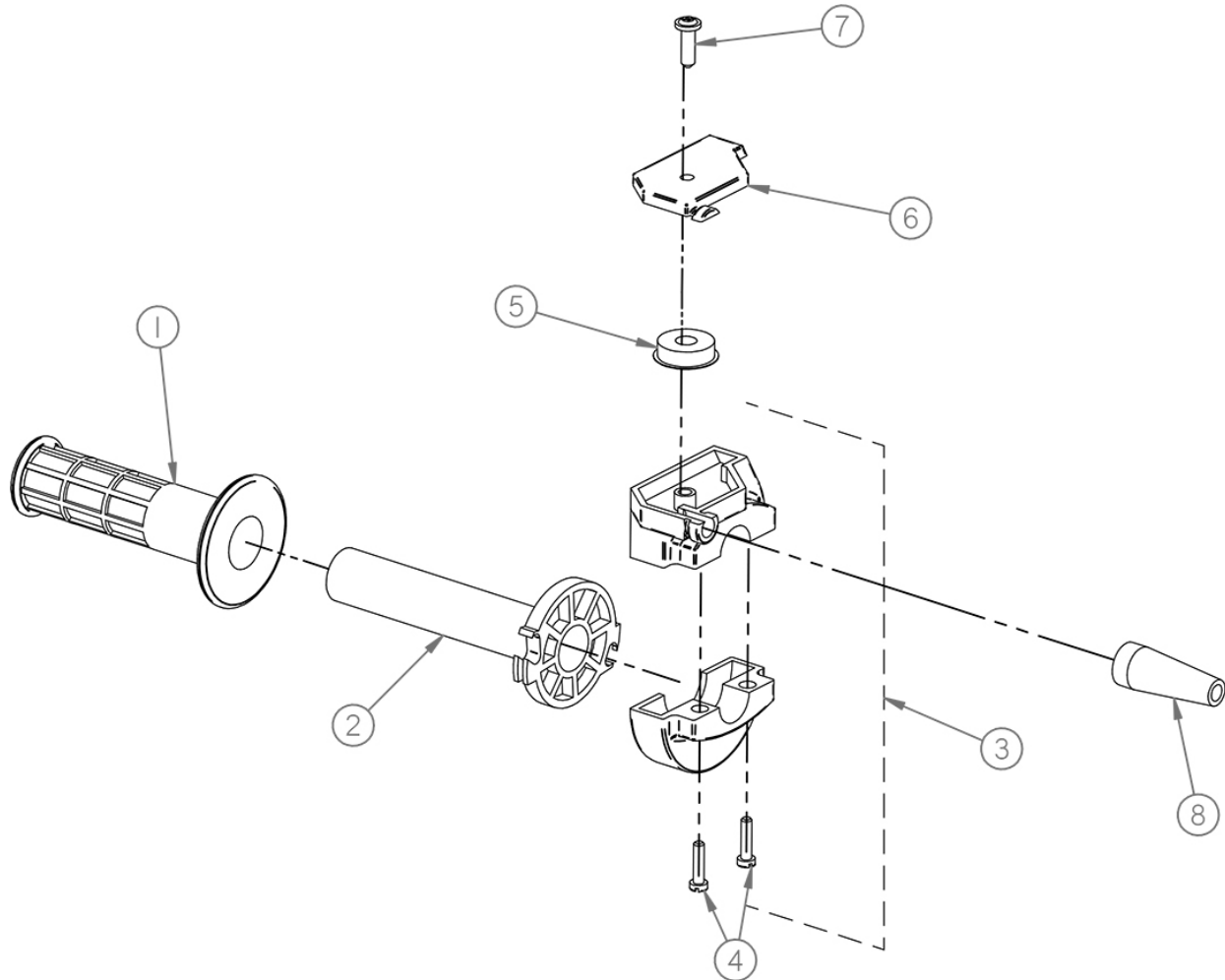

Reference Number	Part Number	Description	Quantity
1	310-0020-030	Grip, Throttle	1
2	310-0030-020-A	Tube, Throttle, W/Grip, (Includes Reference 1)	1
3	310-0030-010-A	Assembly, Body, W/Screws, (Includes Reference 4)	1
4	310-0030-040	Screw, Cheesehead, M5-.8 X 20	2
5	310-0030-070	Sheave, Roller	1
6	310-0030-060	Cover, Top	1
7	310-0030-050	Screw, Self-Tapping	1
8	310-0020-080	Boot, Rubber	1

Replacement Parts Diagram 4400 Series Augers (2 Thru 4 Inch Diameter) For Use With 332H Hole Digger

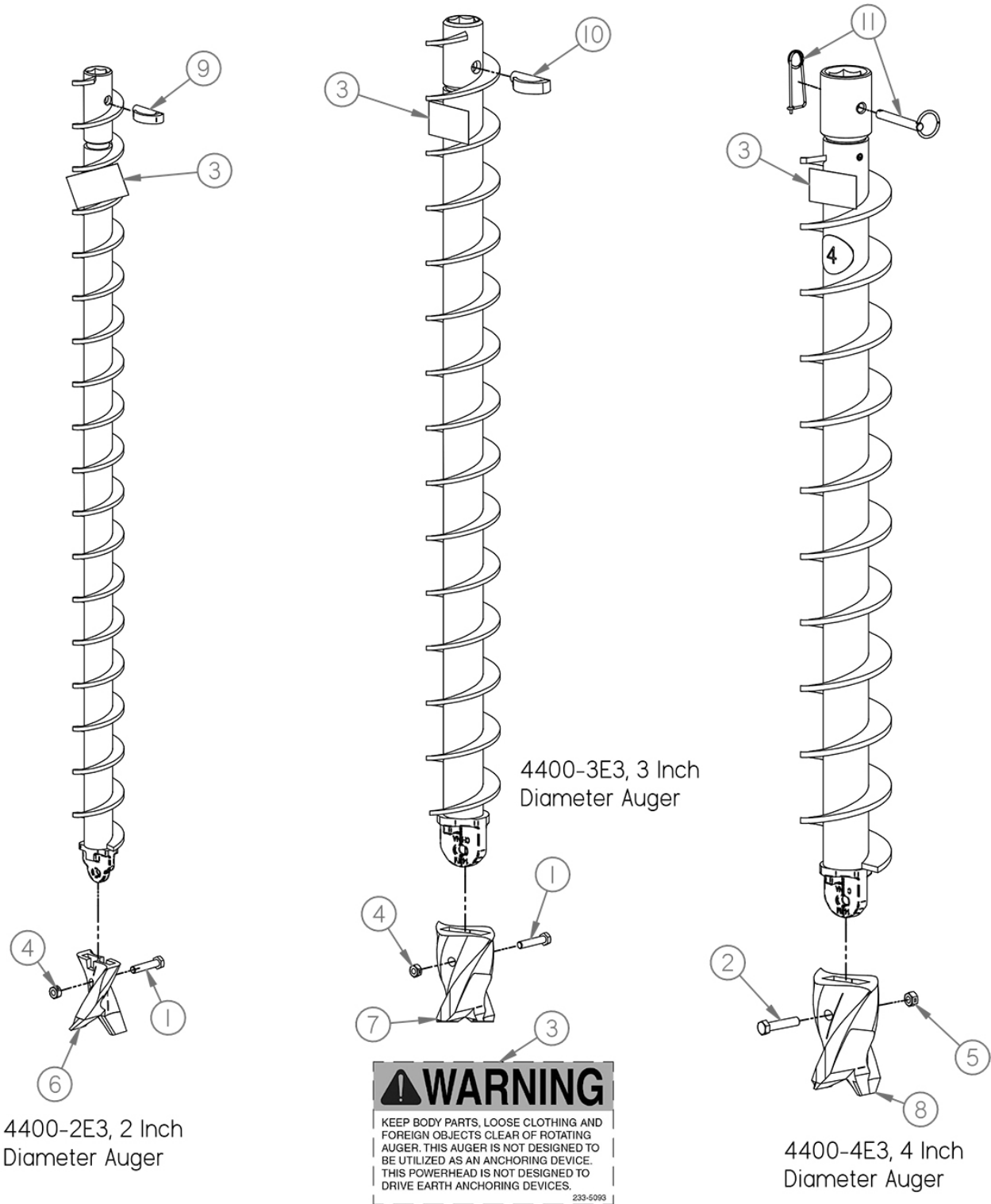

Replacement Parts Diagram 4400 Series Augers (2 Thru 4 Inch Diameter) For Use With 332H Hole Digger

Reference Number	Part Number	Description	Application	Quantity
1	15051200	HHCS, 5/16-18 X 1-1/2, ZY	4400-2E3 Thru 4400-3E3	1
2	15061400	HHCS, 3/8-16 X 1-3/4, ZY	4400-4E4	1
3	233-5093	Decal, Caution, Clear Rotating	All Augers	1
4	52050000	Nut, Lock, 2-Way, 5/16-18, ZY	4400-2E3 Thru 4400-3E3	1
5	52060000	Nut, Lock, 2-Way, 3/8-16, ZY	4400-4E3	1
6	SB25PAK3	Pak3, Bit, Screw, Auger, (Includes Reference 1 & 4)	4400-2E3	1
7	SB35	Bit, Screw, Auger, (Includes Reference 1 & 4)	4400-3E3	1
8	SB45	Bit, Screw, Auger, (Includes Reference 2 & 5)	4400-4E3	1
9	DP-2	Pin, Drive	4400-2E3	1
10	DP-3	Pin, Drive	4400-3E3	1
11	2121PAK3	Pak3, Pin, Auger, .375D	4400-4E3	1

Replacement Parts Diagram 4400 & 4450 Series Augers (6 Thru 18 Inch Diameter) 1-3/8 Inch Hexagon Drive Connection For Use With 332H Hole Digger

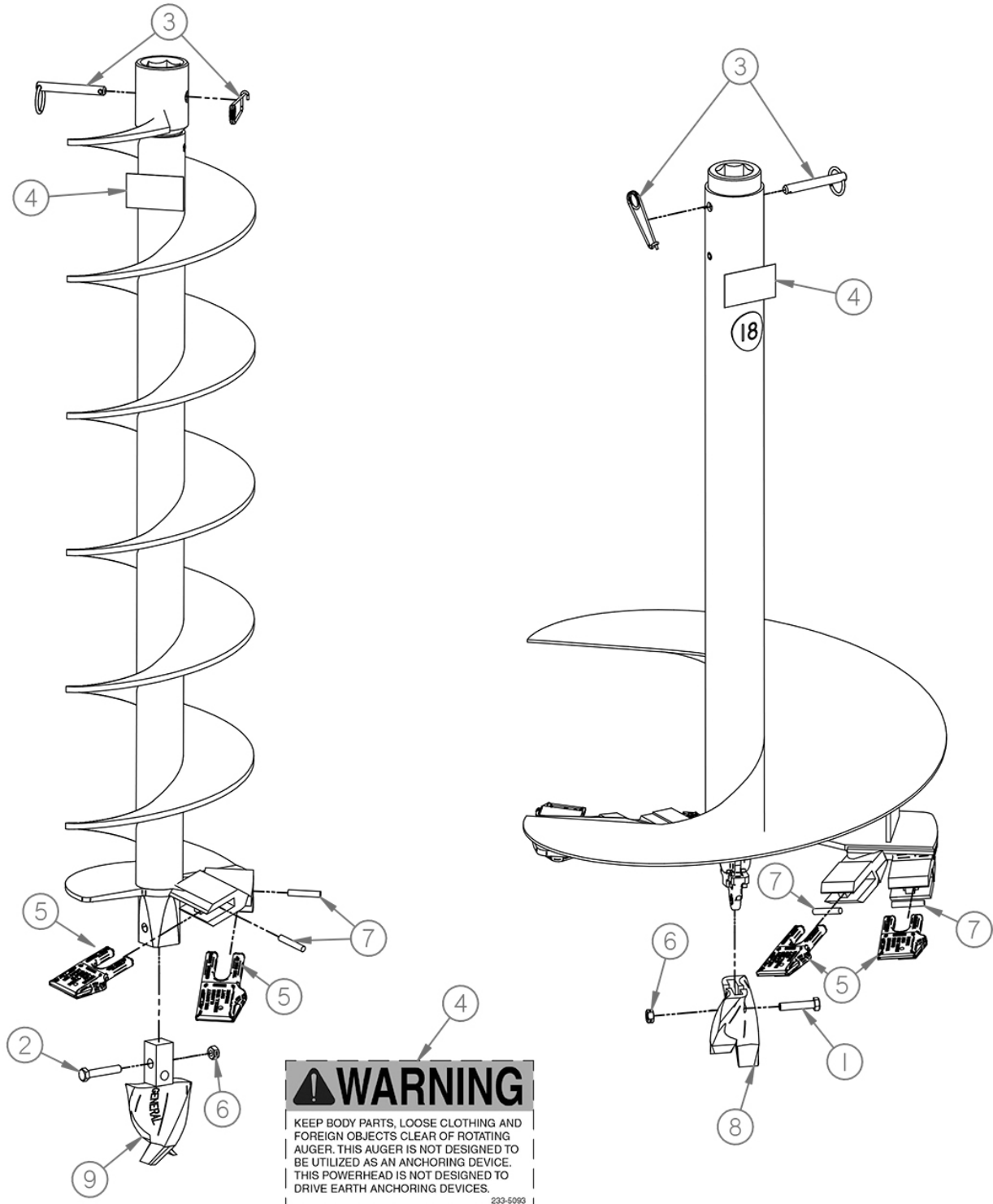

*Replacement Parts Diagram
 4400 & 4450 Series Augers (6 Thru 18 Inch Diameter)
 1-3/8 Inch Hexagon Drive Connection
 For Use With 332H Hole Digger*

Reference Number	Part Number	Description	Application	Quantity
1	15051200	HHCS, 5/16-18 X 1-1/2, ZY	4400-14E3 Thru 4400-18P	1
2	15051400	HHCS, 5/16-18 X 1-3/4, ZY	4450-6E3 Thru 4450-12E3	1
3	2121PAK3	Pak3, Pin, Auger, .375D	4400-6E3 Thru 4400-18P	1
4	233-5093	Decal, Caution, Clear Rotating	All Augers	1
5	35HFCPAK7	Pak7, Tooth, Dirt, Hardfaced, (Includes 7 Each PN: RL, Lock, Rubber)	4450-6E3 Thru 4400-18P	As Req.
6	52050000	Nut, Lock, 2-Way, 5/16-18, ZY	4450-6E3 Thru 4400-18P	1
7	RLPAK21	Pak21, Lock, Rubber	4450-6E3 Thru 4400-18P	As Req.
8	SB25PAK3	Pak3, Bit, Screw, Auger, (Includes Ref. 1 & 6)	4400-14E3 Thru 4400-18P	1
9	SB26PAK3	Pak3, Bit, Screw, Auger, (Includes Ref. 2 & 6)	4450-6E3 Thru 4450-12E3	1

*Replacement Parts Diagram
4400 Series Couplers
(Use With 4400-2E3 and 4400-3E3 Augers)
For Use With 332H & 348H Hole Digger*

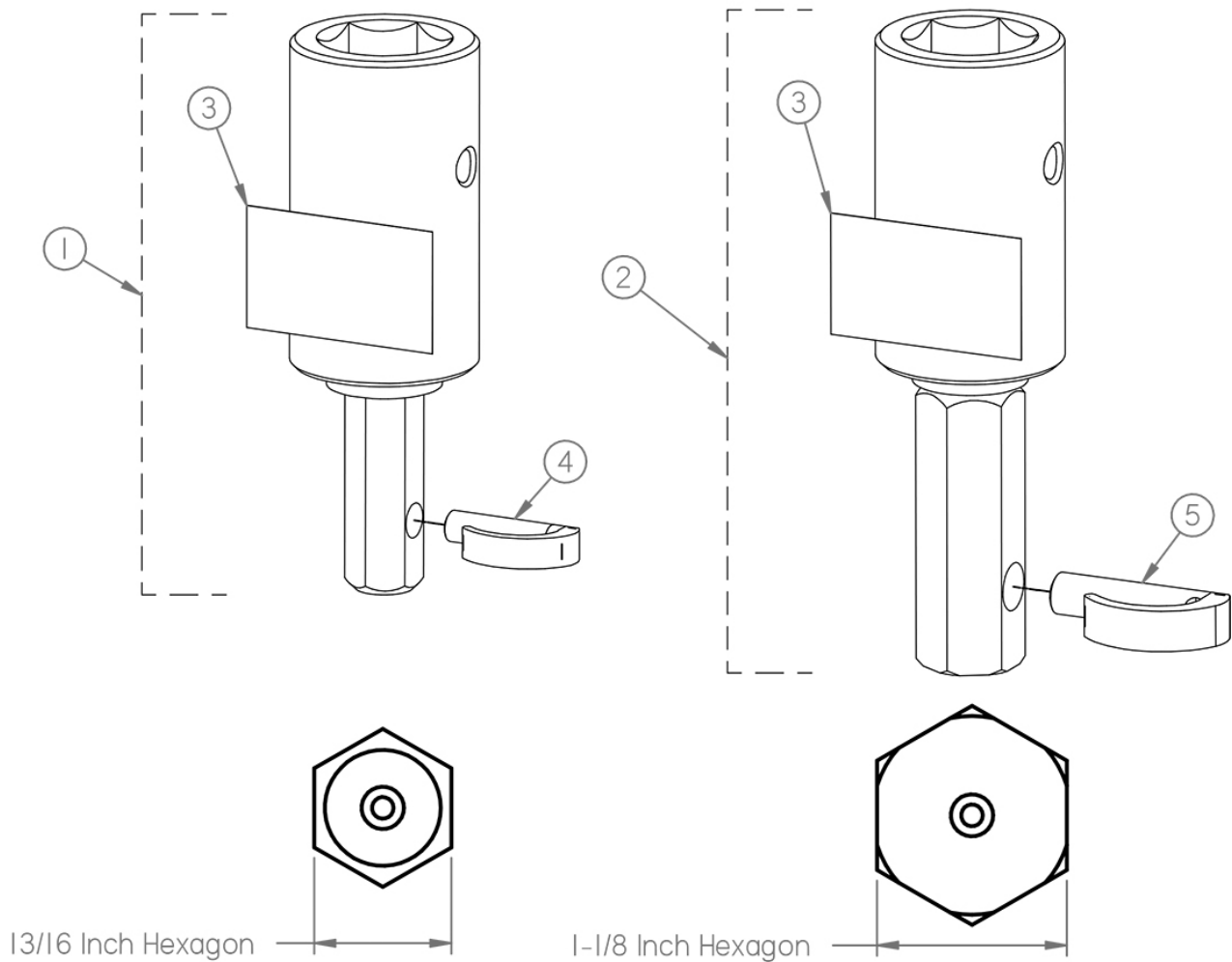

3

! WARNING

KEEP BODY PARTS, LOOSE CLOTHING AND FOREIGN OBJECTS CLEAR OF ROTATING AUGER. THIS AUGER IS NOT DESIGNED TO BE UTILIZED AS AN ANCHORING DEVICE. THIS POWERHEAD IS NOT DESIGNED TO DRIVE EARTH ANCHORING DEVICES.

233-5093

*Replacement Parts Diagram
 4400 Series Couplers
 (Use With 4400-2E3 and 4400-3E3 Augers)
 For Use With 332H Hole Digger*

Reference Number	Part Number	Description	Quantity
1	4400-2CLR	CPLR, 1-3/8 Box To 13/16 Pin, (Includes Ref. 3 & 4) (For Use With 4400-2E3 Auger)	1
2	4400-3CLR	CPLR, 1-3/8 Box To 1-1/8 Pin, (Includes Ref. 3 & 5) (For Use With 4400-3E3 Auger)	1
3	233-5093	Decal, Caution, Clear Rotating	1
4	DP-2	Pin, Drive	1
5	DP-3	Pin, Drive	1

*Replacement Parts Diagram
 PSD & PLDBH Series Augers (4 Thru 12 Inch Diameter)
 7/8 Inch Square Drive Connection
 For Use With 348H Hole Digger*

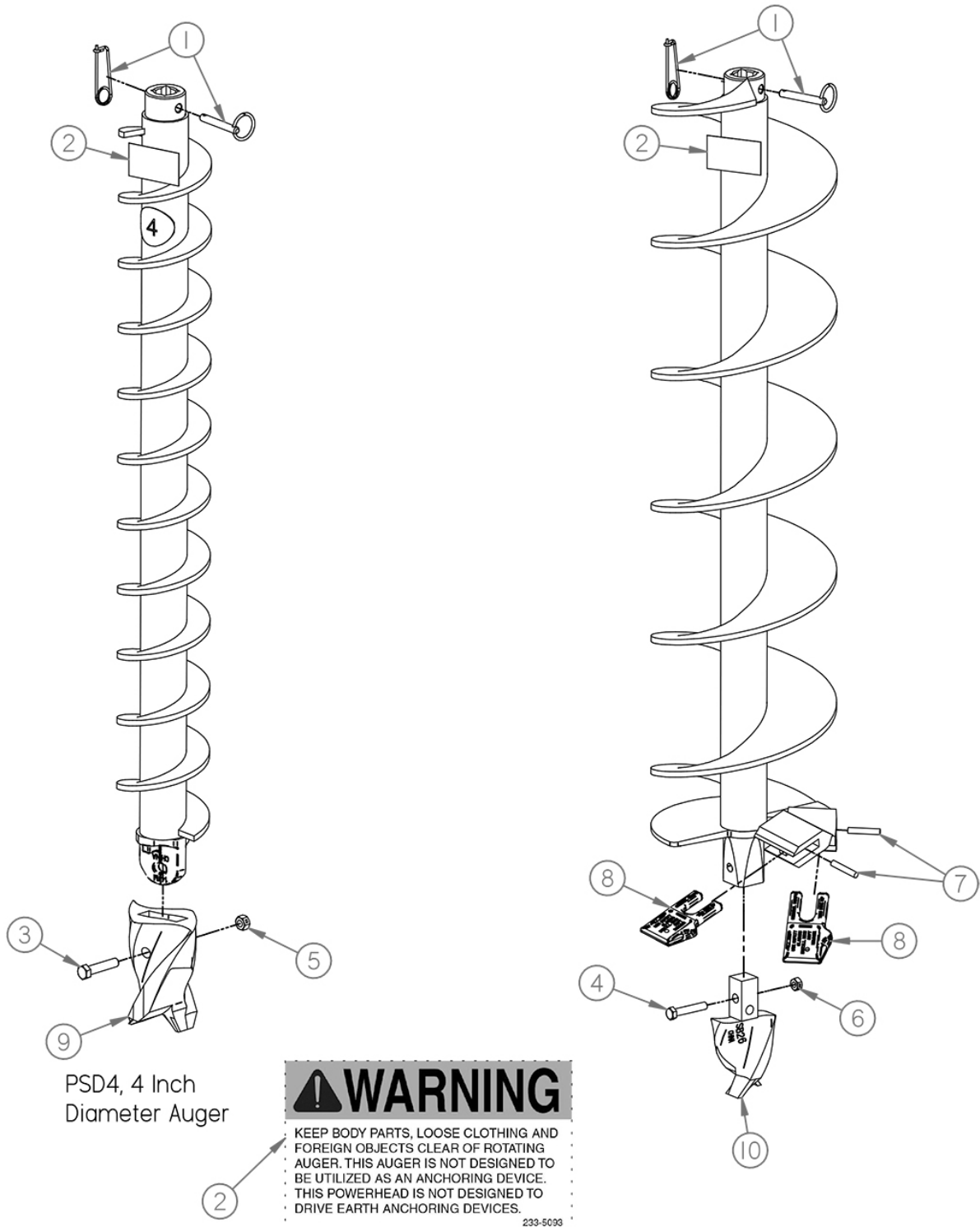

*Replacement Parts Diagram
 PSD & PLDBH Series Augers (4 Thru 12 Inch Diameter)
 7/8 Inch Square Drive Connection
 For Use With 348H Hole Digger*

Reference Number	Part Number	Description	Application	Quantity
1	2021PAK3	Pak3, Pin, Auger, .312D	PSD4 Thru PLDBH12	1
2	233-5093	Decal, Caution, Clear Rotating	All Augers	1
3	15061400	HHCS, 3/8-16 X 1-3/4, ZY	PSD4	1
4	15051400	HHCS, 5/16-18 X 1-3/4, ZY	PLDBH6 Thru PLDBH12	1
5	52060000	Nut, Lock, 2-Way, 3/8-16, ZY	PSD4	1
6	52050000	Nut, Lock, 2-Way, 5/16-18, ZY	PLDBH6 Thru PLDBH12	1
7	RLPAK21	Pak21, Lock, Rubber	PLDBH6 Thru PLDBH12	As Req.
8	35HFCAK7	Pak7, Tooth, Dirt, Hardfaced, (Includes 7 Each PN: RL, Lock, Rubber)	PLDBH6 Thru PLDBH12	As Req.
9	SB45	Bit, Screw, Auger, (Includes Ref. 3 & 5)	PSD4	1
10	SB26PAK3	Pak3, Bit, Screw, Auger, (Includes Ref. 4 & 6)	PLDBH6 Thru PLDBH12	1

Replacement Parts Diagram PSD Series Augers (14 Thru 18 Inch Diameter) 7/8 Inch Square Drive Connection For Use With 348H Hole Digger

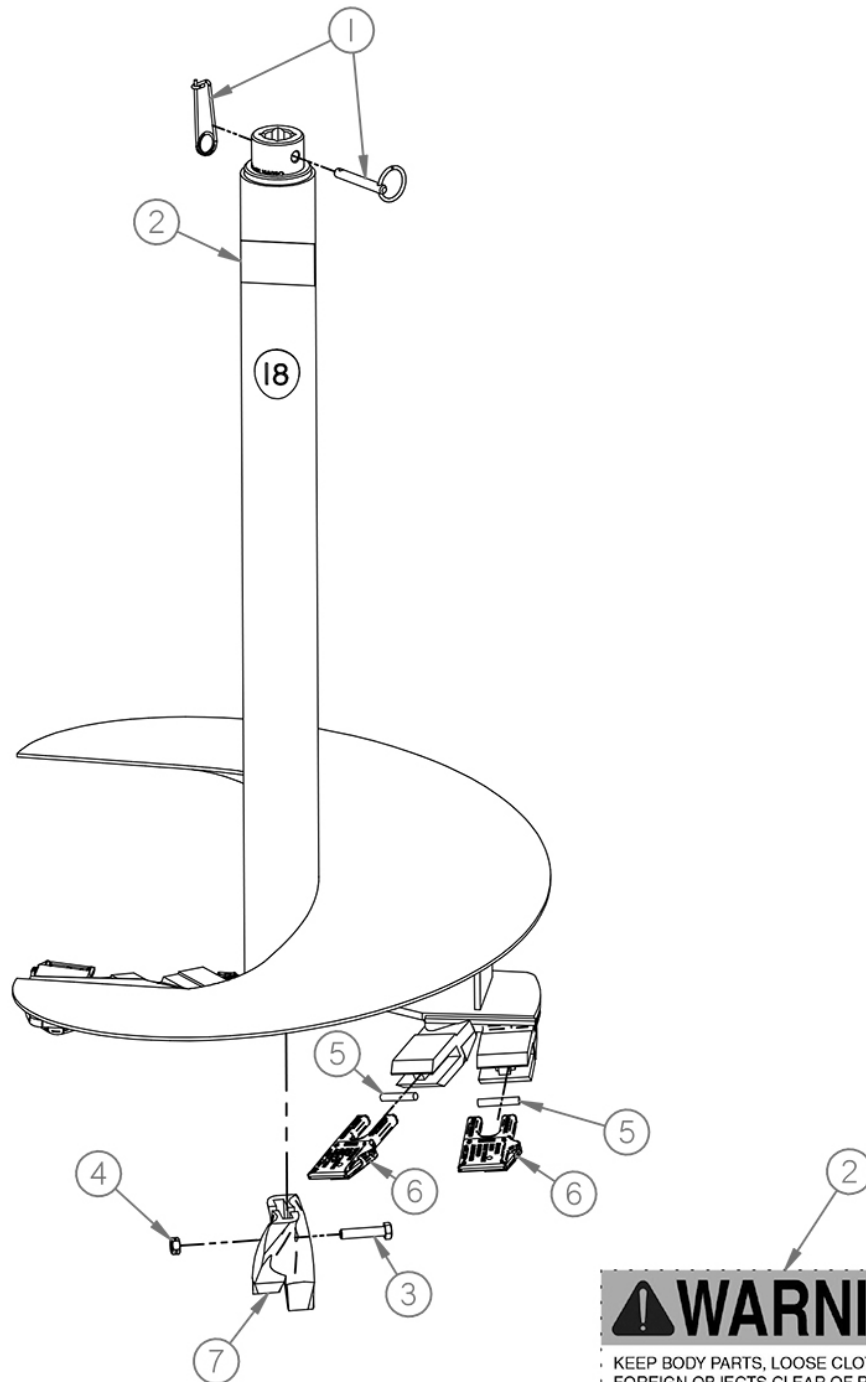

⚠ WARNING
KEEP BODY PARTS, LOOSE CLOTHING AND FOREIGN OBJECTS CLEAR OF ROTATING AUGER. THIS AUGER IS NOT DESIGNED TO BE UTILIZED AS AN ANCHORING DEVICE. THIS POWERHEAD IS NOT DESIGNED TO DRIVE EARTH ANCHORING DEVICES.
233-5093

*Replacement Parts Diagram
 PSD Series Augers (14 Thru 18 Diameter)
 7/8 Inch Square Drive Connection
 For Use With 348H Hole Digger*

Reference Number	Part Number	Description	Application	Quantity
1	2021PAK3	Pak3, Pin, Auger, .312D	PSD14 Thru PSD18P	1
2	233-5093	Decal, Caution, Clear Rotating	All Augers	1
3	15051200	HHCS, 5/16-18 X 1-1/2, ZY	PSD14 Thru PSD18P	1
4	52050000	Nut, Lock, 2-Way, 5/16-18, ZY	PSD14 thru PSD18P	1
5	RLPAK21	Pak21, Lock, Rubber	PSD14 Thru PSD18P	As Req.
6	35HFCAK7	Pak7, Tooth, Dirt, Hardfaced, (Includes 7 Each PN: RL, Lock, Rubber)	PSD14 Thru PSD18P	As Req.
7	SB25PAK3	Pak3, Bit, Screw, Auger, (Includes Ref. 3 & 4)	PSD14 Thru PSD18P	1

THIS PAGE INTENTIONALLY
LEFT BLANK